

# GROK

News 2014





**GROK**

---

# Index

/2

colgantes  
pendants  
suspensions  
pendelleuchten  
pendenti  
pendentes  
подвесные светильники  
lampy wiszące



**Aura 6**



**Balloons 10**

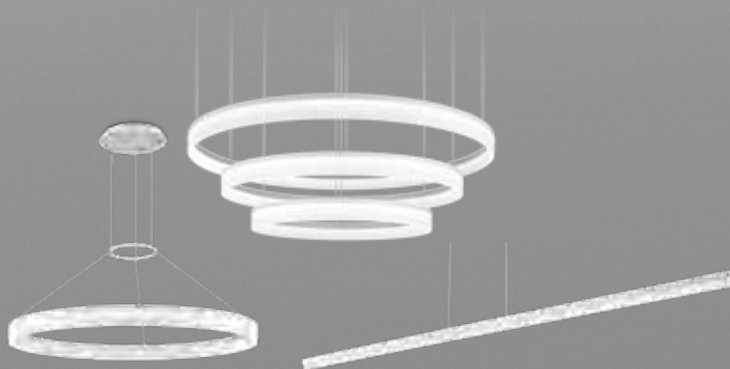

**Circ 20**



**Clear 16**



**Leaf 8**



**Net 18**



**Sixties 12**

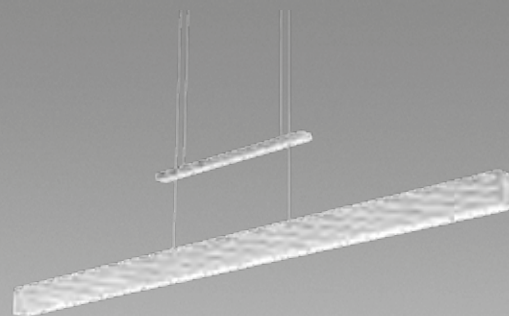

**Stream 26**

plafones  
ceiling fixtures  
plafoniers  
deckenleuchten  
plafoniere  
plafones  
потолочные светильники  
lampy sufitowe



**Ibis 36**

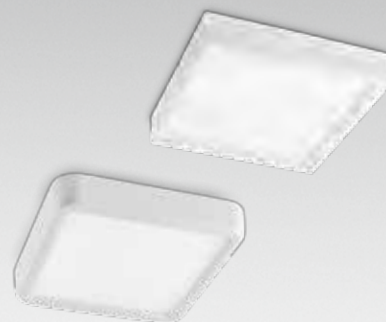

**Net 38**

---

# Index

---

/3

apliques  
wall fixtures  
apliques  
wandleuchten  
lampade da parete  
apliques  
настенные светильники  
lampy ścienne

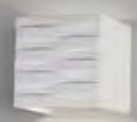
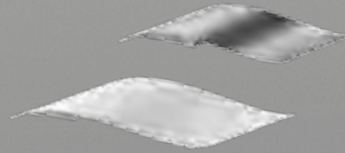
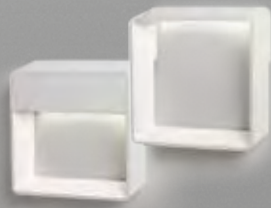

---

**Cell me 30**

**Rizz 34**

**Stream 26**

---

sobremesas  
table lamps  
lampes de table  
tischleuchten  
lampade da tavolo  
candeeiros de mesa  
настольные светильники  
lampy biurkowe



---

**Hall 48**

---

pies salón  
floor lamps  
lampadaires  
stehleuchten  
lampade da terra  
candeeiros de sala  
торшеры  
lampy podłogowe



---

**Ace 44**

**Bold 46**

**Circ 42**

**Hall 48**

---

# Aura new

---

*design* Josep Patsí

---



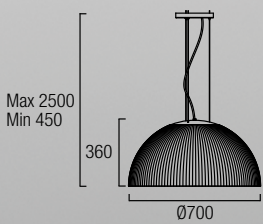
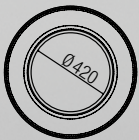

**00-1942-BW-M3**

LED 40W  
 3000K included 4.440 lm<sup>N</sup>  
 LED 10W  
 RGB included

--	--	--	--



# Aura

/7



Sistema de doble iluminación independiente. /  
Independent paired lighting system. /  
Système à double éclairage indépendant. /  
Unabhängiges doppeltes Beleuchtungssystem. /  
Sistema a doppia illuminazione indipendente. /  
Sistema de iluminação dupla independente. /  
Система независимого двойного освещения. /  
Niezależny łączony system oświetleniowy.

/8

# Leaf <sup>new</sup>

---

*design* WIS Design

---

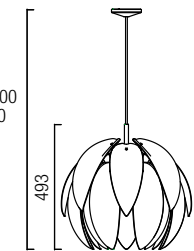
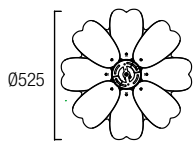

Max 2000  
Min 600

**00-3813-BW-08**  
**00-3813-BW-34**

1 x E-27 Max. 30W / Max.L=176mm.  
Fluorescent-LED  
Recommended LED ACT-FLL-050

BW 08 34

ST PMMA FELT SHADE





# Balloons

/11

design Josep Patsí

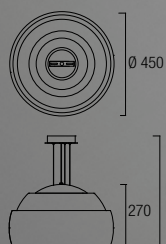









00-4348-21-F9  
00-4348-BW-F9 **new**

1 x E-27 Max. 150W / Max. L=195mm Ø=60mm  
Halogen - Fluorescent - LED

Recommended LED ACT-FLL-050

#### 00-4348-BW-F9:

-  3 pantallas interiores intercambiables incluidas
-  3 interchangeable indoor screens included
-  3 abat-jour intérieurs et interchangeables inclus.
-  3 Innenschirme zum Auswechseln nicht im Lieferumfang enthalten
-  Include 3 parabole interne intercambiabili
-  3 abat-jour interiores e intermutáveis incluidos
-  3 сменных абажура в комплекте
-  3 zamienne abażury wewnętrzne w komplecie

BW 21

ST TEX TIL GLASS OPAL 3 DIF





# Sixties <sup>new</sup>

/13

*design Josep Patsí*

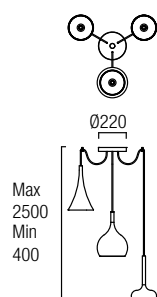

**00-3806-CI-CI**

LED CREE 26,1W  
3000K included 2.793 lm<sup>N</sup>



ST



# Sixties



00-3687-CI-CI

LED CREE 8,7W  
3000K included 931 lm<sup>(9)</sup>

Max 2500  
Min 400

Ø240

350

00-3688-CI-CI

LED CREE 8,7W  
3000K included 931 lm<sup>(9)</sup>

Max 2500  
Min 400

Ø200

350

00-3689-CI-CI

LED CREE 8,7W  
3000K included 931 lm<sup>(9)</sup>

Max 2500  
Min 400

Ø200

350







# Clear

/17

design Josep Patsí

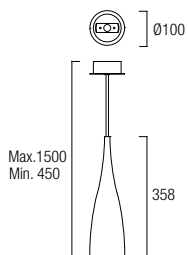

00-2872-05-M2

00-2872-25-M2 **new**

00-2872-78-M2

1x E-27 Max. 50W / Max. L=170mm Ø=60mm

Halogen - Fluorescent - LED

Recommended E-27 PAR-20 50W



71-2232-14-14

Conector de carril  
Track connector  
Connecteur de rail  
Schienenstecker  
Connettore di binario  
Conector de calha  
Трековый соединитель  
Złączka szyny



05 25 78

ST PC  
DIF



26

/18

# Net <sup>new</sup>

*design Josep Patsí*

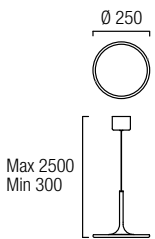

**00-3685-BW-M1**

LED 15W  
3000K Included 1.665 lm<sup>90</sup>

BW

AL PS  
DIP







# Circ <sup>new</sup>

design Grok Team

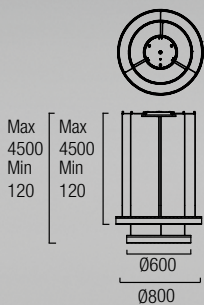

00-3647-BW-M3 (Standard)

LED 53W  
3000K included 5.883 lm<sup>(N)</sup>

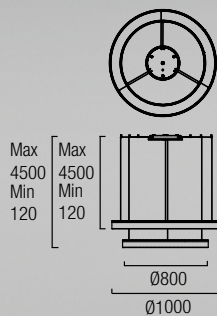

00-3648-BW-M3 (Standard)

LED 67W  
3000K included 7.437 lm<sup>(N)</sup>

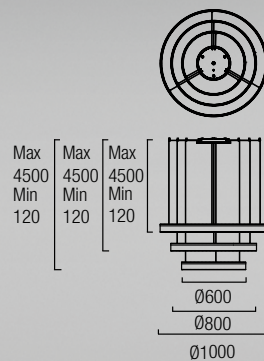

00-3649-BW-M3 (Standard)

LED 89W  
3000K included 9.879 lm<sup>(N)</sup>



71-2241-00-00

Controlador con mando a distancia para **Versiones Standard**  
Controller with remote control for **Standard Version**







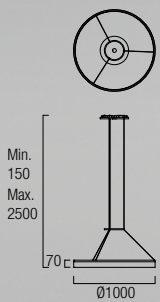

**00-3642-BW-M3** (Standard) new  
**00-3646-BW-M3** (Dimmable 1-10V)

LED 36W  
 3000K included 3.996 lm<sup>(N)</sup>

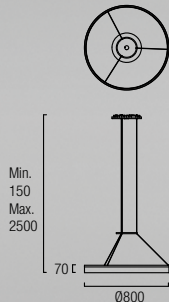

**00-0002-BW-M3** (Standard)  
**00-0642-BW-M3** (Dimmable 1-10V)

LED 31W  
 3000K included 3.441 lm<sup>(N)</sup>

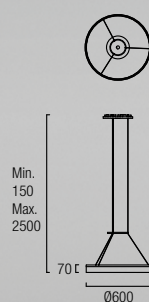

**00-0001-BW-M3** (Standard)  
**00-0641-BW-M3** (Dimmable 1-10V)

LED 22W  
 3000K included 2.442 lm<sup>(N)</sup>



**71-2241-00-00**

Controlador con mando a distancia  
 para **Versiones Standard**  
 Controller with remote control for  
**Standard Version**



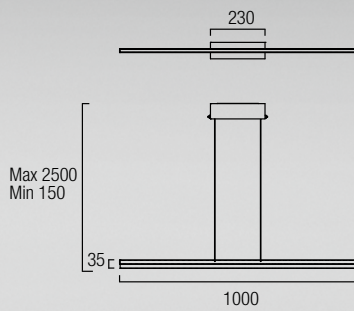
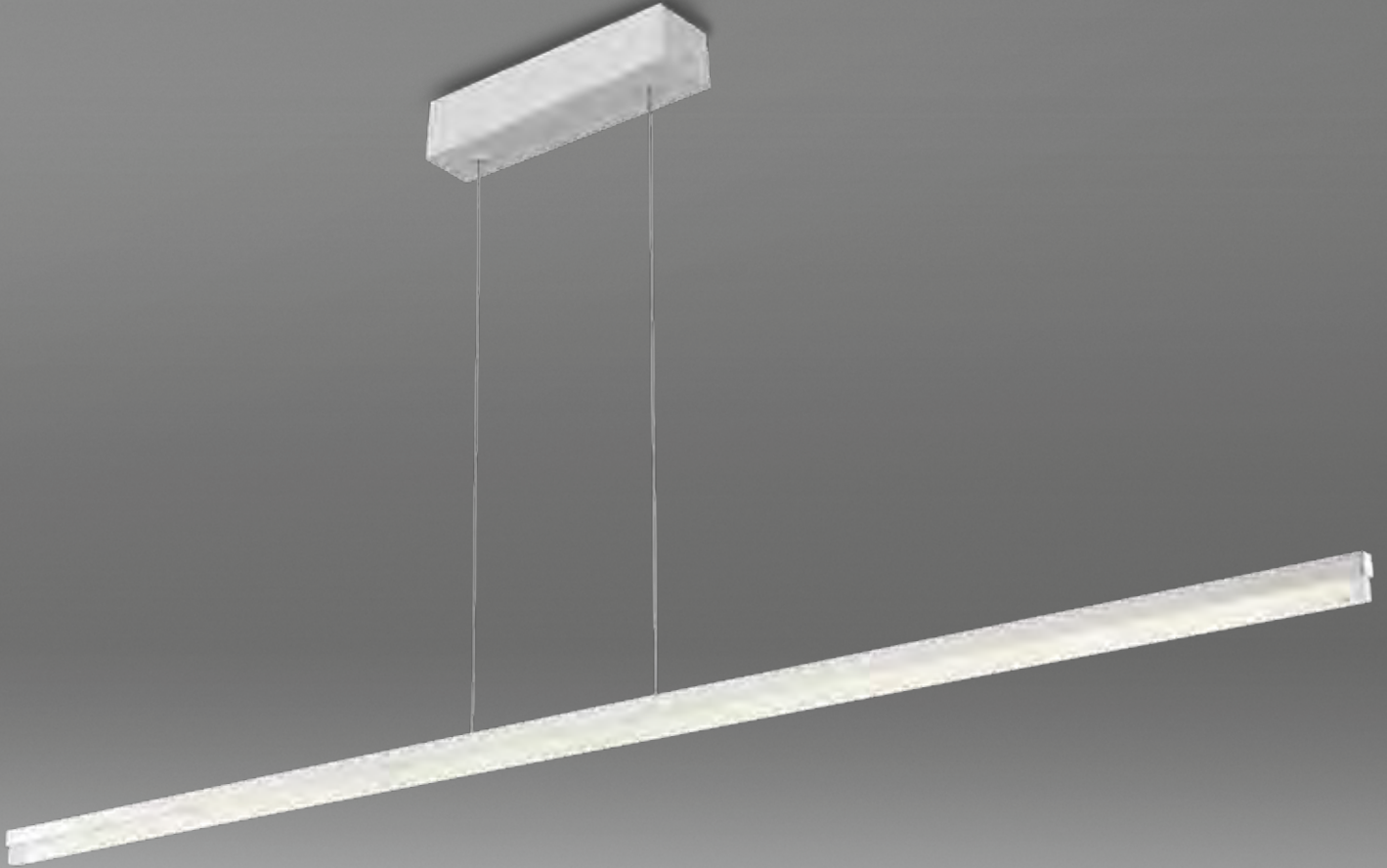

**00-2934-BW-M3** (Standard)  
**00-3643-BW-M3** (Dimmable 1-10V)

LED 18W  
 3000K included 1.998 lm<sup>(N)</sup>

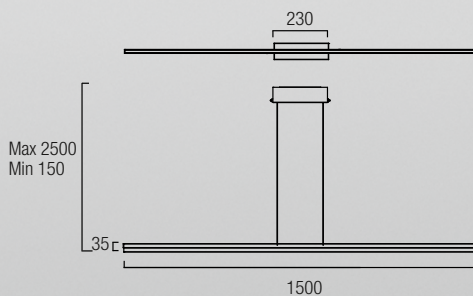

**00-2935-BW-M3** (Standard)  
**00-3644-BW-M3** (Dimmable 1-10V)

LED 27W  
 3000K included 2.997 lm<sup>(N)</sup>



**71-2241-00-00**

Controlador con mando a distancia para  
**Versiones Standard**  
 Controller with remote control for  
**Standard Version**





/26

# Stream <sup>new</sup>

---

*design* Josep Patsí

---





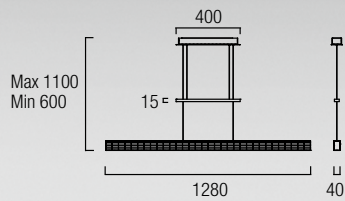

**00-2924-BW-M1**

LED CREE 27,5W (Down) 3.052 lm<sup>(N)</sup>  
LED CREE 12,5W (Up) 1.387 lm<sup>(N)</sup>  
3000K included

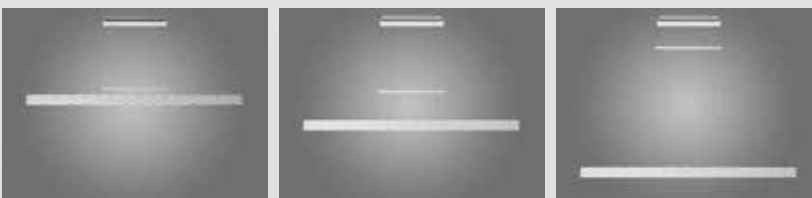
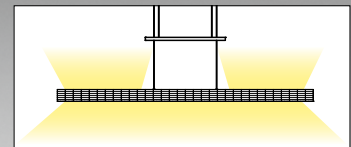
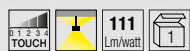

Sistema de doble iluminación independiente.  
Independent paired lighting system.  
Système à double éclairage indépendant.  
Unabhängiges doppeltes Beleuchtungssystem.  
Sistema a doppia illuminazione indipendente.  
Sistema de iluminação dupla independente.  
Система независимого двойного освещения.  
Niezależny łączony system oświetleniowy.

# Stream

/29

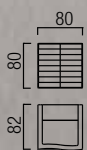

**05-2924-BW-M3**

LED CREE 4W  
3000K included 428 lm<sup>N</sup>



BW

PUR AL PMMA  
DIF







# Cell me <sup>new</sup>

/31

*design Francesc Vilaró*

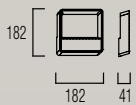

**05-3544-BW-BW**  
**05-3544-25-25**

LED 3,4W  
3000K included 377 lm<sup>90</sup>

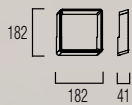
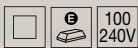

**71-3544-BW-BW**  
**71-3544-25-25**

LED 3,4W  
3000K included 377 lm<sup>90</sup>



Accesorio para realizar combinaciones.  
Accessory for making combinations.  
Accessoire pour la réalisation de combinaisons.  
Accessorio per combinazioni.  
Zubehör für Kombinationen.  
Acessório para realizar combinações.  
Аксессуар для создания комбинаций.  
Akcesorium do wykonywania zestawień.

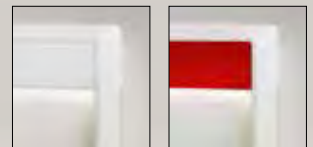

2 tapas frontales intercambiables incluidas.  
It includes 2 interchangeable front covers.  
2 caches frontaux interchangeables inclus.  
inkl. 2 austauschbare vordere Abdeckungen.  
Contiene 2 coperchi frontali intercambiabili.  
Incluídas 2 tampas frontais inter-cambiáveis.  
Включает 2 сменные лицевые панели.  
Zawiera dwa wymienne fronty.

BW 25

AL PMMA  
DIF

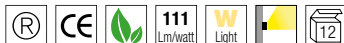

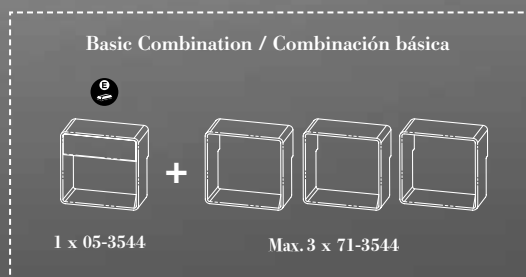
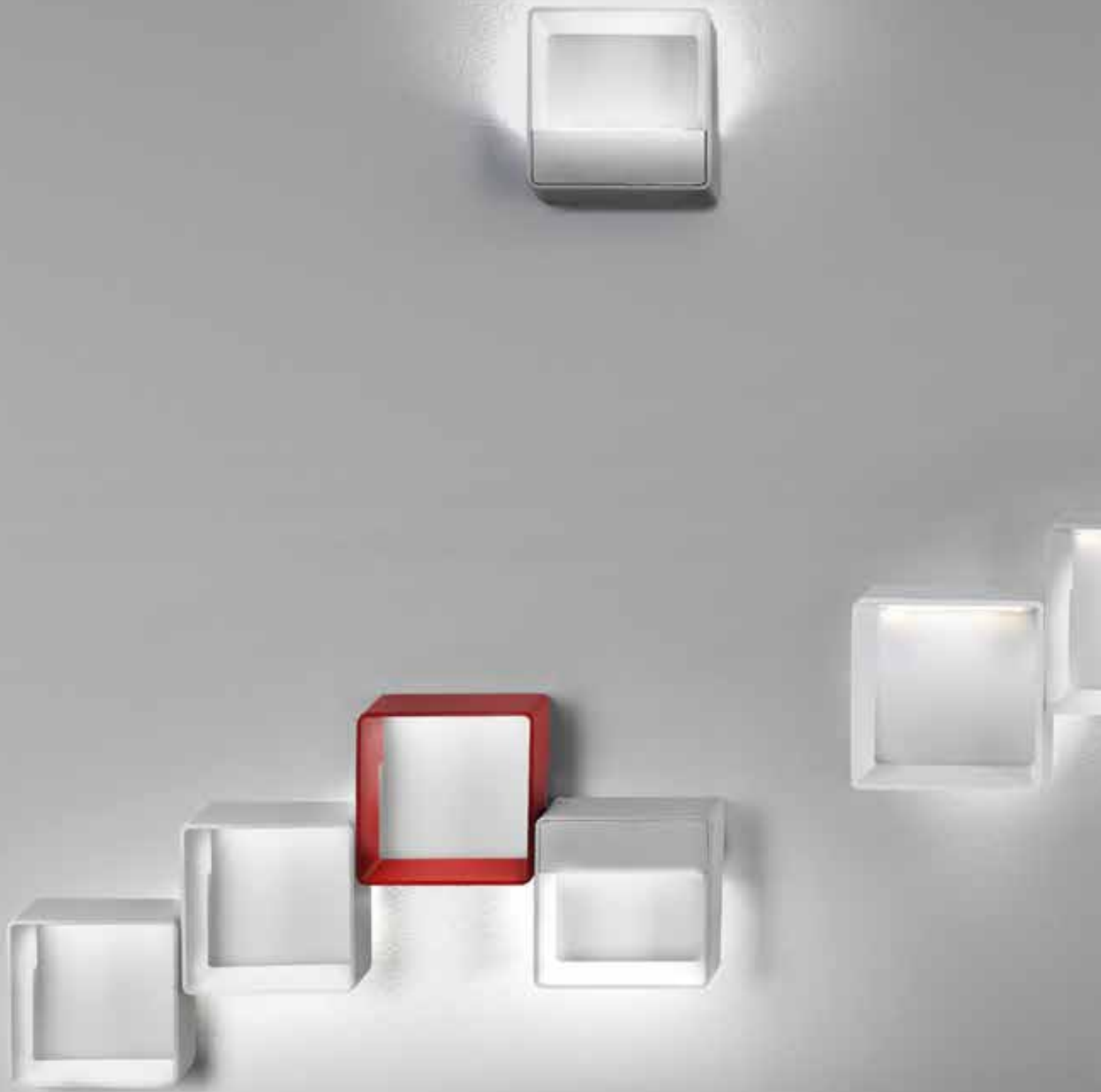

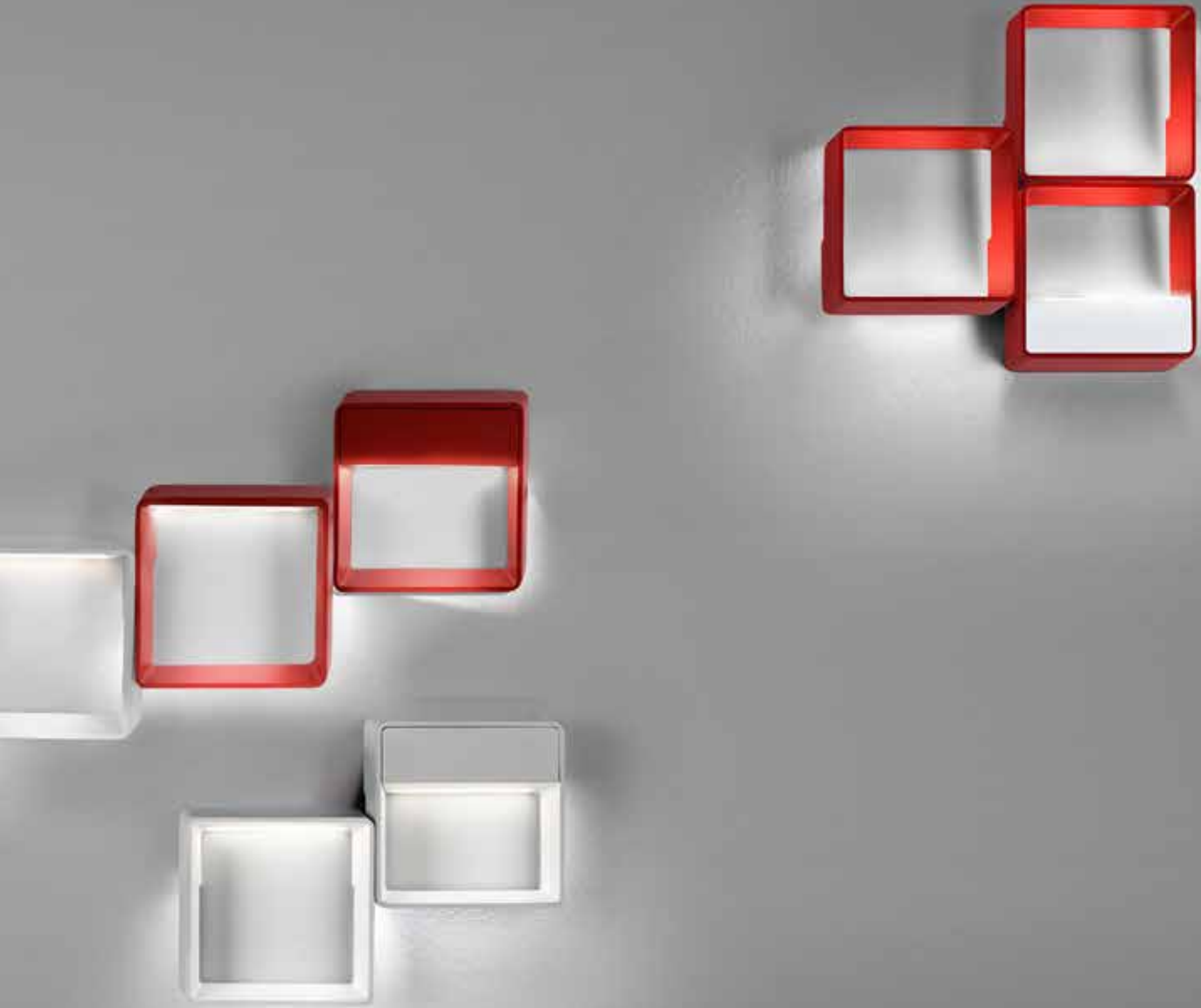

1  
pieza /  
piece



05-3544



71-3544

2  
piezas /  
pieces

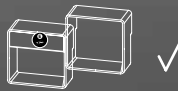

05-3544 + 71-3544

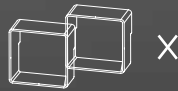

71-3544 + 71-3544

3/4  
piezas /  
pieces

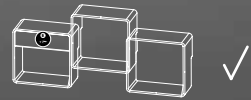

05-3544 + 2 x 71-3544

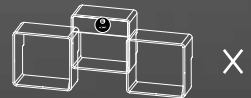

05-3544 + 2 x 71-3544

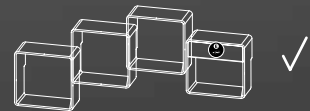

05-3544 + 3 x 71-3544

# Rizz

*design* Ramón Valls

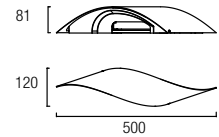
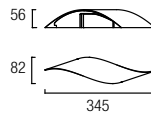

**05-1819-AF-AF** new  
**05-1819-BW-BW**

LED CREE 6W  
 3000K included 642 lm<sup>(N)</sup>

**05-1822-AF-AF** new  
**05-1822-BW-BW**

LED CREE 10W  
 3000K included 1.070 lm<sup>(N)</sup>



Su especial diseño permite múltiples combinaciones.  
 Its special design allows for multiple combinations.

Esquema de conexión  
 Connection scheme

AF BW

AL PMMA  
 DIF







When constant evolution becomes an icon \* When constant evolution becomes an icon

**Ibis**  
**LED**  
since 1990

# Ibis

/37

*design Grok team*

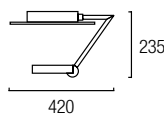

**15-3231-BW-BW**  
**15-3231-81-81**



LED CREE 24,8W  
3000 K included 2.654 lm<sup>90</sup>

81 BW

AL PMMA  
DIP



190





# Net <sup>new</sup>

design Josep Patsí

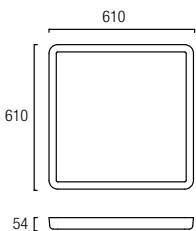

**15-0003-BW-M1** (Standard)  
**15-0835-BW-M1** (Dimmable 1-10V)

LED 55W  
3000K included 6.105 lm<sup>®</sup>

PUR

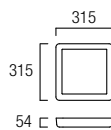

**15-3536-BW-M1** (Standard) <sup>new</sup>

LED 30W  
3000K Included 3.330 lm<sup>®</sup>

PUR



**71-2241-00-00**

Controlador con mando a distancia para **Versiones Standard**  
Controller with remote control for **Standard Version**



BW

PS  
DIP



100  
240V



111  
Lm/watt



22

18

184

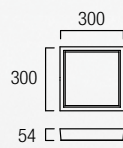
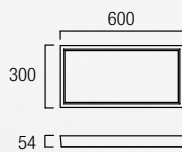
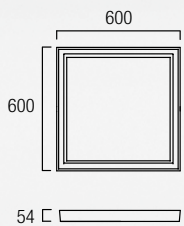
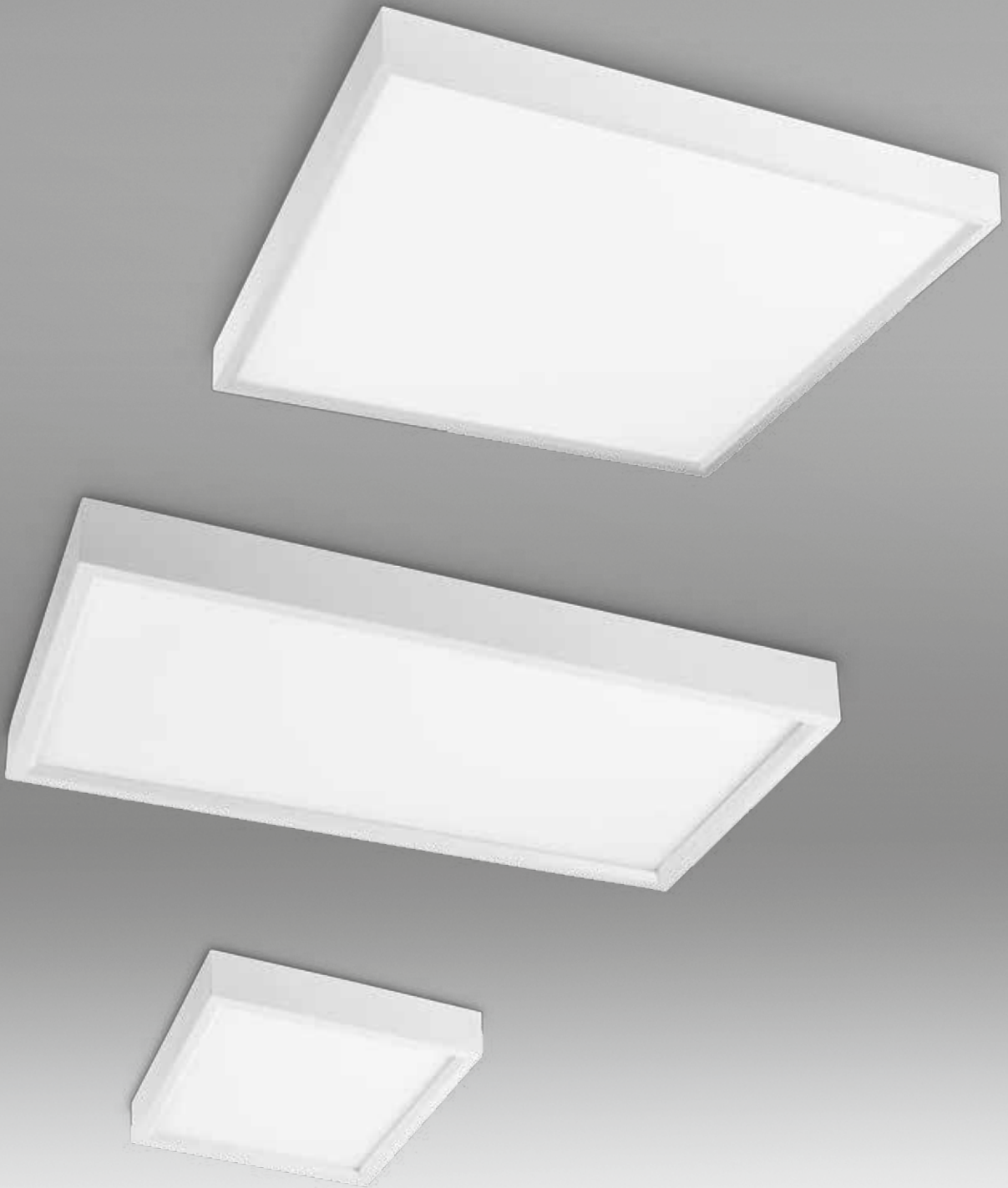

**15-3538-BW-M1** (Standard) **new**  
**15-3825-BW-M** (Dimmable 1-10V)

LED 55W  
 3000K Included 6.105 lm<sup>(n)</sup>

AL

**15-3537-BW-M1** (Standard) **new**

LED 45W  
 3000K Included 4.995 lm<sup>(n)</sup>

AL

**15-3535-BW-M1** (Standard) **new**

LED 30W  
 3000K Included 3.330 lm<sup>(n)</sup>

AL



**71-2241-00-00**

Controlador con mando a distancia para  
**Versiones Standard**  
 Controller with remote control for  
**Standard Version**





# Circ<sup>new</sup>

design Grok Team

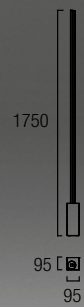

**25-2934-BW-M3**

LED 27W  
3000K included 2.997 lm<sup>®</sup>



**71-2934-BW-BW**

Accesorio para zonas transitadas  
Accessory for transit areas  
Accessoire pour zones de passage  
Zubehör für begehbare Bereiche  
Accesorio per zone ad alto transito  
Accessório para zonas de passagem.  
Аксессуар для использования в зонах  
общественного пользования  
Akcesoria do stref pieszych

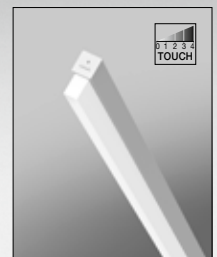

--	--	--	--



# Ace <sup>new</sup>

*design Josep Patsí*

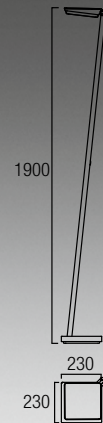
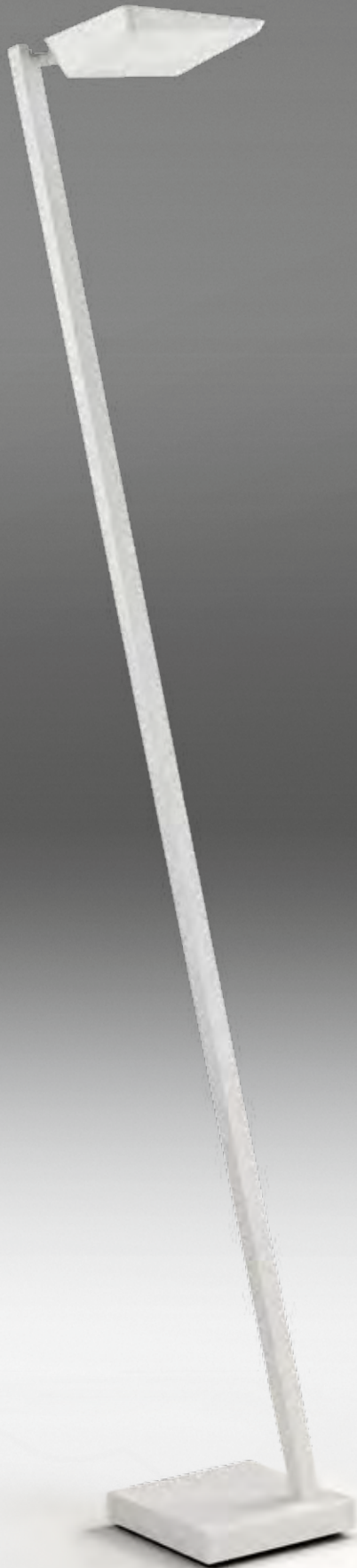

**25-2410-BW-M3**

LED CREE 28W  
3000K included 2.996 lm<sup>90</sup>

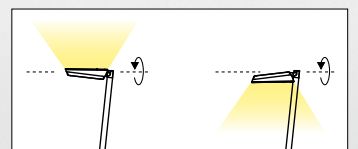
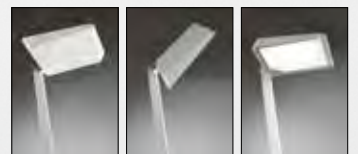

			<p>176</p>
--	--	--	------------



/46

# Bold<sup>new</sup>

*design Estudi Ribaudí*

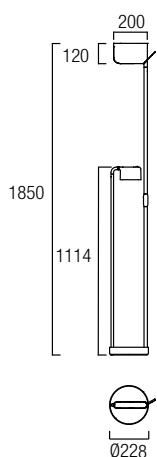

25-3230-CH-M3

LED CREE 19,8W  
3000K included 2.119 lm<sup>(N)</sup>  
LED CREE 6.6W  
3000K included 706 lm<sup>(N)</sup>



CH

AL PMMA  
DIF



100  
240V



CE



107  
lm/watt

W  
Light









Top diffuser

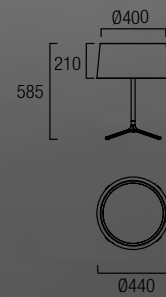

**10-1940-05-T004**  
**10-1940-BW-14**

3 x E-27 Max. 18W / Max.L=140mm. Ø52mm  
Fluorescent-LED  
**Recommended LED ACT-FLL-050**

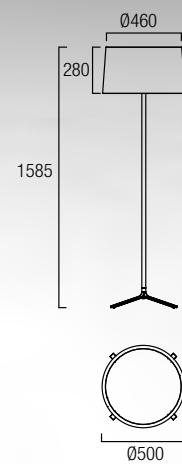

**25-1940-05-T004**  
**25-1940-BW-14**

3 x E-27 Max. 30W / Max.L=176mm. Ø60mm  
Fluorescent-LED  
**Recommended LED ACT-FLL-050**



# Hall new

*design Nahrang design*

/49





 Clase I • Class I • Classe I • Classe I • Classe I • Classe I • Класс I • Klasa I

 Clase II • Class II • Classe II • Classe II • Classe II • Classe II • Класс II • Klasa II

 Clase III • Class III • Classe III • Classe III • Classe III • Classe III • Класс III • Klasa III

 Fabricado según normas de seguridad y electromagnetismo de Europa • Manufactured according to the set safety and electromagnetism standards of Europe • Fabriqués en conformité avec les normes de sécurité et d'électromagnétique de l'Europe • Hergestellt nach den in Europa geltenden Sicherheits- und elektromagnetischen Bestimmungen • Tutti i prodotti fabbricati rispettano le norme di sicurezza e di elettromagnetismo europee • Fabricado de acordo com as normas de segurança e electromagnetismo da Europa • Изготовлено в соответствии с европейскими стандартами для электронного и электромагнитного оборудования. • Wyprodukowane zgodnie z zasadami europejskich standardów bezpieczeństwa i elektromagnetyki.

 Resistente al hilo incandescente a 850°C • Resistance to incandescent wire at 850°C • Tenue au feu 850°C • Glühdrahtbeständig auf 850°C • Resistente a filo incandescente 850°C • Resistente ao fio incandescente a 850°C • Прошло испытание спиралью накаливания 850°C • Odpornośćna drut żarowy o temperaturze 850°C

 Equipo electrónico • Electronic gear • Equipement électronique • Elektronische Vorschaltgerät • Dispositivo elettronico • Aparelho electrónico • Электронный балласт • Osprzet elektroniczny

 Dirección del halo de luz • Halo light direction • Direction du faisceau lumineux • Halo Lichtrichtung • Direzione del Fascio di luce • Direcção do feixe de luz • Направление света. • Kierunek tuny światła

 Uds. de embalaje • Items per box • Unité d'emballage • Verpackungseinheiten • Unità d'imballaggio • Uds. de embalagem • Количество единиц в коробке • Sztuk w pudełku

 Modelos registrados • Registered models • Modèles enregistrés • Eingetragene Modelle • Modelli registrati • Modelos registrados • Зарегистрированные модели • modele zastrzezone

 Bajo consumo • Energy saving • Économie d'énergie • Energiesparlampe • Risparmio energetico • Baixo consumo • Энергосберегающий • Energooszczędny

 Luz cálida • Warm light • Lumière chaude • Warmweißes Licht • Luce calda • Luz quente • Теплый свет • Ciepłe światło

 Luz RGB • RGB light • Lumière RGB • RGB Licht • Luce RGB • Luz RGB • Свет RGB • Światło RGB

 Lumens/watios • Lumens/Watts • Lumens/watt • Lumen/Watt • Lumen/Watt • Lúmenes/watts • Lumenów/watów • Люмены/ватты

 Material difusor • Diffuser material • Material diffusant • Difuseur Material • Materiale diffusore • Material difusor • Материал диффузора • Material rozszarżający

 Material pantalla • Shade material • Matériels Abat-jour • Material des Schirmes • Materiale del paralume • Material Abajur • Материал абажура • Material abażuru

 Regulador de intensidad • Dimmer • Régulateur d'intensité • Mit dimmer • Con regolatore d'intensità • Com regulador de intensidade • Регулятор яркости • Ściemniacz

 Regulador de intensidad táctil • Touch dimmer • Variateur d'intensité tactile • Regler zur Einstellung der Berührungintensität • Regolatore tattile dell'intensità • Variador de intensidade táctil. • Сенсорный диммер • Ściemniacz dotykowy

 Interruptor de encendido • On/off switch • Interrupteur simple allumage • Schalter • Interruttore di accensione • Interruptor on/off • Клавишный выключатель • Włącznik

 Orientable • Adjustable • Orientable • Verstellbar • Orientabile • Ajustável • Регулируемый • Regulowane

 Mando a distancia • Remote control • Télécommande • Fernbedienung • Telecomando • Comando à distância • Пульт управления • Pilot zdalnego sterowania

 Controlador con mando a distancia • Controller with remote control • Contrôleur avec télécommande • Controller mit Fernbedienung • Regolatore con telecomando • Controlador com comando à distância • Контролер с дистанционным управлением • Nastawnik z pilotem zdalnego sterowania

 Pilas incluidas • Batteries included • Piles fournies • Batterien inklusive • Pile incluse • Pilhas incluidas • Батарейки в комплекте • Łącznie z bateriami

 Flujo nominal basado en condiciones reales de trabajo (25°C<Ts<90°C). • Nominal flux based on real working conditions (25°C<Ts<90°C). • Flux nominal basé sur des conditions de fonctionnement réelles (25°C<Ts<90°C). • Nominal-Lichtfluss basierend auf tatsächlichen Betriebsbedingungen (25°C<Ts<90°C). • Flusso nominale basato su condizioni reali di funzionamento (25°C<Ts<90°C). • Fluxo nominal baseado em condições reais de trabalho (25°C<Ts<90 °C). • Номинальный поток на основе фактических условий работы (25°C<Ts<90°C). • Znamionowy strumień oparty na rzeczywistych warunkach pracy (25°C<Ts<90°C).

 Número de página en catálogo general • Number of pages in the general catalogue • Numéro de page dans le catalogue général • Seitennummer vom Gesamtkatalog • Número di página nel catálogo generale • Número de página em catálogo geral • Номер страницы в генеральном каталоге • Numer strony w katalogu głównym

PMMA	PMMA • PMMA • PMMA • PMMA • PMMA • PMMA • ПММА • РММА
AL	Aluminio • Aluminium • Aluminium • Aluminium • Alluminio • Aluminio • Алюминий • Alumi- nium
FELT	Feltro • Felt • Feutre • Filz • Stoffa di lana • Feltro • Фильтр • Filc
PC	Policarbonato • Polycarbonate • Polycarbonate • Polykarbonat • Policarbonato • Policar- bonato • Поликарбонат • Poliwęglan
PS	Poliestireno • Polystyrene • Polystyrène • Polystyrol • Polistirolo • Poliestireno • Рассеиватель • Polistyren
PUR	Poliuretano • Polyurethane • Polyuréthane • Polyurethan • Poliuretano • Poliuretano • Поулиритан • Poliuretan
ST	Acero • Steel • Acier • Stahl • Acciaio • Aço • Сталь • Stal
TEXTIL	Tela • Fabric • Tissu • Stoff • Tela • Tela • Ткань • Tkanina

05 T004	Negro • Black • Noir • Schwarz • Nero • Preto • Черный • Czarny
08	Verde • Green • Vert • Grün • Vert • Verde • ЗЕЛЕНЫЙ • Zielony
14	Blanco • White • Blanc • Weiß • Bianco • Branco • Белый • Biały
21	Cromo • Chrome • Chrome • Chrom • Cromo • Cromo • Хром • Chromowany
25 25	Rojo • Red • Rouge • Rot • Rosso • Vermelho • Красный • Czerwony
34	Grey • Grey • Gris • Grau • Grigio • Cinzento • Серый • Szary
78	Lacado blanco • White lacquered • Laqué en blanc • Weiß lackiert • Laccato bianco • Lacado branco • Белый лак • Polakierowany na biało

81	Níquel satinado • Satin nickel • Nickel satiné • Nickel satiniert • Níchel satinato • Níquel acetinado • Сатинированный никель • Szczotkowany nikiel
AF	Aluminio satinado • Satin aluminium • Alumi- nium satiné • Aluminium matt • Alluminio sati- nato • Aluminio acetinado • Сатинированный алюминий • Aluminium satynowe
BW	Blanco mate • Matt white • Blanc mate • Weiß matt • Bianco opaco • Branco fosco • Белый матовый • Matowy biały
CH	Gris metalizado • Metallic grey • Gris métallisé • Metallisch-grau • Grigio metallizzato • Cinza metalizado • Серый металл • Metaliczny szary
CI	Marrón • Brown • Marron • Braun • Marrone • Marrom • Коричневый • Brązowy

REF.	COLLECTION	PAG.
00-0001	Circ	23
00-0002	Circ	23
00-0641	Circ	23
00-0642	Circ	23
00-1942	Aura	6
00-2872	Clear	17
00-2924	Stream	28
00-2934	Circ	24
00-2935	Circ	24
00-3642	Circ	23
00-3643	Circ	24
00-3644	Circ	24
00-3646	Circ	23
00-3647	Circ	21
00-3648	Circ	21
00-3649	Circ	21
00-3685	Net	18
00-3687	Sixties	14
00-3688	Sixties	14
00-3689	Sixties	14
00-3806	Sixties	13
00-3813	Leaf	9

REF.	COLLECTION	PAG.
00-4348	Balloons	11
05-1819	Rizz	34
05-1822	Rizz	34
05-2924	Stream	29
05-3544	Cell me	31
10-1940	Hall	48
15-0003	Net	39
15-0835	Net	39
15-3231	Ibis	37
15-3535	Net	40
15-3536	Net	39
15-3537	Net	40
15-3538	Net	40
15-3825	Net	40
25-1940	Hall	48
25-2410	Acc	44
25-2934	Circ	42
25-3230	Bold	46
71-2232	Accessory	17
71-2241	Accessory	21, 23, 24, 39, 40
71-2934	Accessory	42
71-3544	Cell me	31



**LEDS-C4, S.A.**

Afuera s/n  
25750 Torà (Lleida)  
SPAIN  
[www.leds-c4.com](http://www.leds-c4.com)

**España**

Tel.: 973 468 101  
Fax.: 973 468 129  
e-mail: [spain@leds-c4.com](mailto:spain@leds-c4.com)

**France**

Tel.: + 34 973 468 130  
Fax.: + 34 973 468 129  
e-mail: [france@leds-c4.com](mailto:france@leds-c4.com)

**Portugal**

Tel.: + 34 973 468 130  
Fax.: + 34 973 468 129  
e-mail: [portugal@leds-c4.com](mailto:portugal@leds-c4.com)

**Europe**

Tel.: + 34 973 468 102  
Fax.: + 34 973 468 106  
e-mail: [europe@leds-c4.com](mailto:europe@leds-c4.com)

**América Latina**

Tel.: + 34 973 468 115  
Fax.: + 34 973 468 106  
e-mail: [latinamerica@leds-c4.com](mailto:latinamerica@leds-c4.com)

**USA - Canada**

Tel.: +34 973 468 109  
Fax: +34 973 468 106  
e-mail: [usa@leds-c4.com](mailto:usa@leds-c4.com)

**Asia - Pacific & Africa**

Tel.: + 34 973 468 116  
Fax.: + 34 973 468 106  
e-mail: [asiapacific@leds-c4.com](mailto:asiapacific@leds-c4.com) - [africa@leds-c4.com](mailto:africa@leds-c4.com)

**Middle East Countries**

Tel.: + 34 973 468 108  
Fax.: + 34 973 468 106  
e-mail: [middleeast@leds-c4.com](mailto:middleeast@leds-c4.com)







Afuera s/n  
25750 Torà (Lleida)  
SPAIN

[www.leds-c4.com](http://www.leds-c4.com)